

DCC Decoder Tester

Before fitting a new DCC decoder into one of your locomotives, it makes sense to check that it is operational. This can be done with the simple tester shown in the schematic overleaf, which is constructed from a set of resistors and light-emitting diodes. Any green and red LEDs can be used, and all resistors, with the exception of R1 are 0.5 watt rated. R1 should have a 2 watt rating as a minimum (and preferably 3 watt), since it is designed to protect your decoder against short-circuits, and may have to withstand the full DCC track voltage – nominally 14 volts for HO-scale.

Connections to the track and the decoder can be made using flying leads from the tester, terminated in miniature crocodile clips (preferably insulated to avoid inadvertent short circuits). Connect to the decoder first, then attach the final two leads to the track, or direct to the outputs from your DCC power booster. Switch SW1 should be in the open position as shown, so that the decoder is protected by resistor R1. [Later, when you are sure that the decoder is functioning correctly, you can close SW1, shorting out R1 and allow the full track voltage to be applied to the decoder. This will let you program the decoder directly, if you so desire, while it is still attached to the tester.]

Both LEDs L1a and L1b should light if a suitable DCC signal for testing your decoder is present on the track (14 volts AC). If a DC voltage is applied to the track then only one of these LEDs will light, depending on the polarity. The other LEDs are driven from the outputs of the decoder under test. New decoders come with their address set to the default value of 03, so send DCC commands to this address and check that the appropriate LEDs light –

L2a = Motor Forward	L5 = Function 1
L2b = Motor Reverse	L6 = Function 2
L3 = Forward Light	L7 = Function 3 (if present)
L4 = Reverse Light	L8 = Function 4 (if present)
	L9 = Function 5 (if present)

A suggested layout for constructing the tester on stripboard is shown on the page following the schematic.

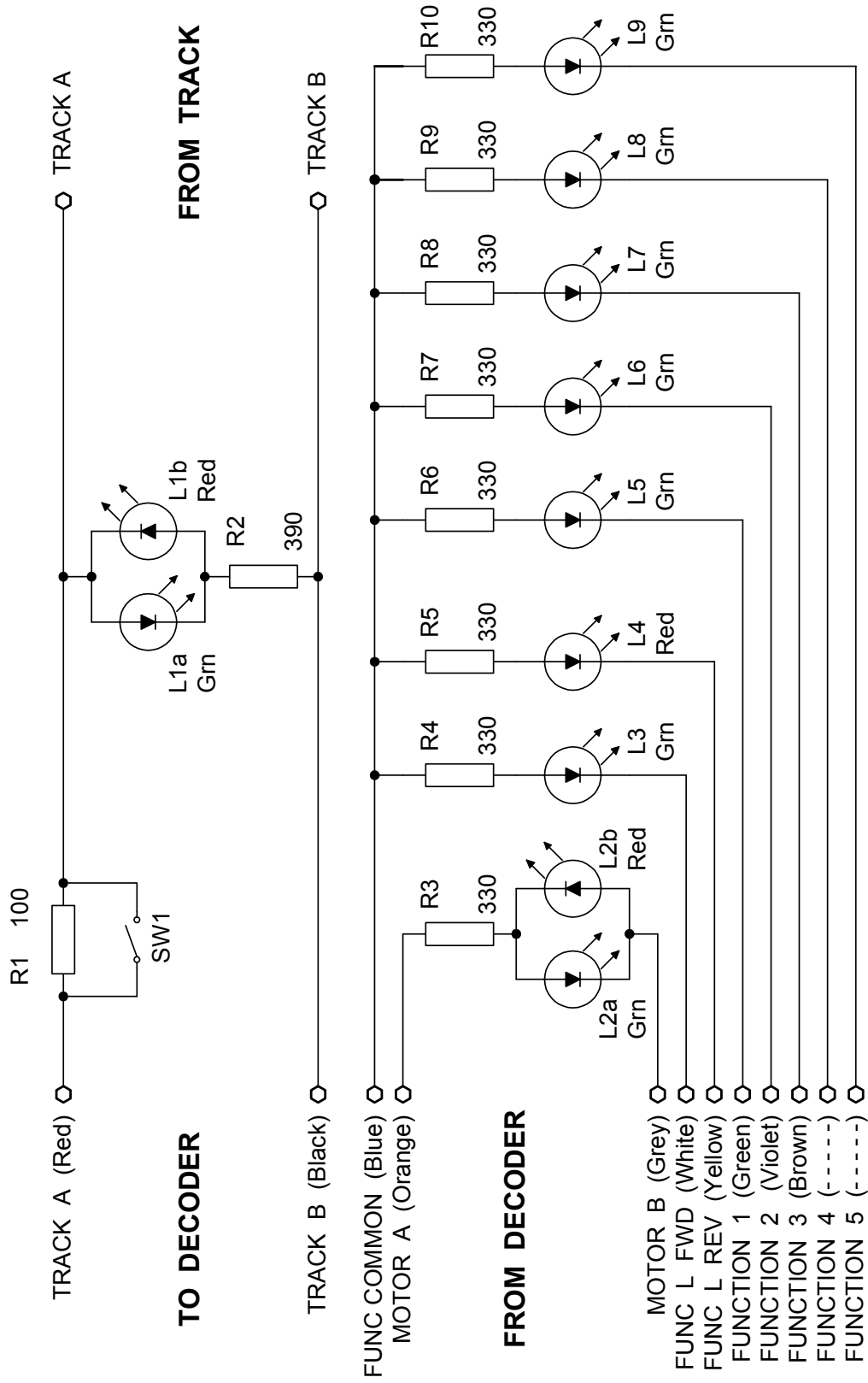

Track Decoder Tester

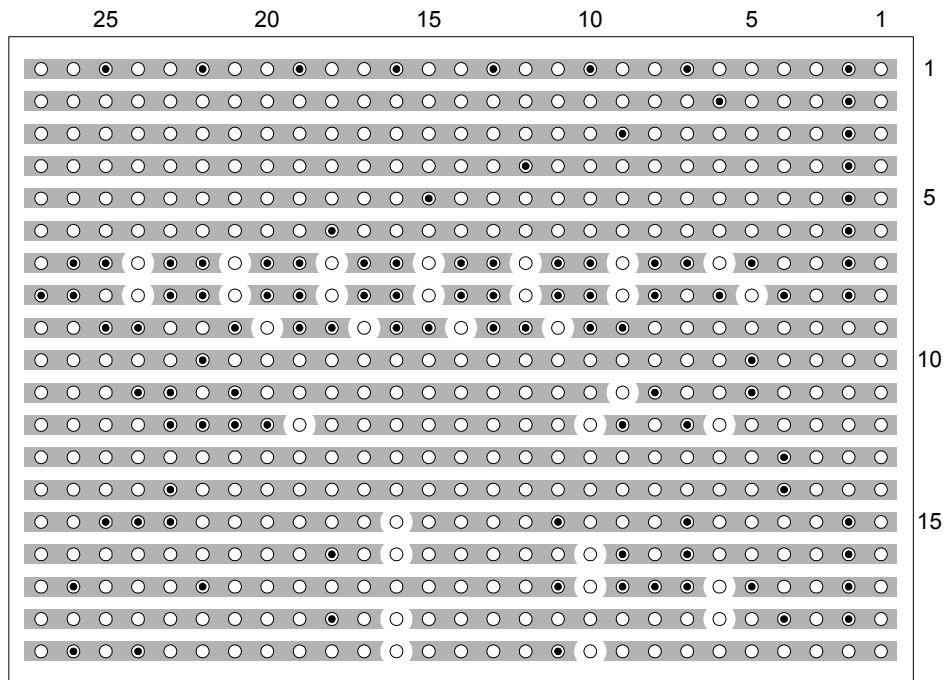
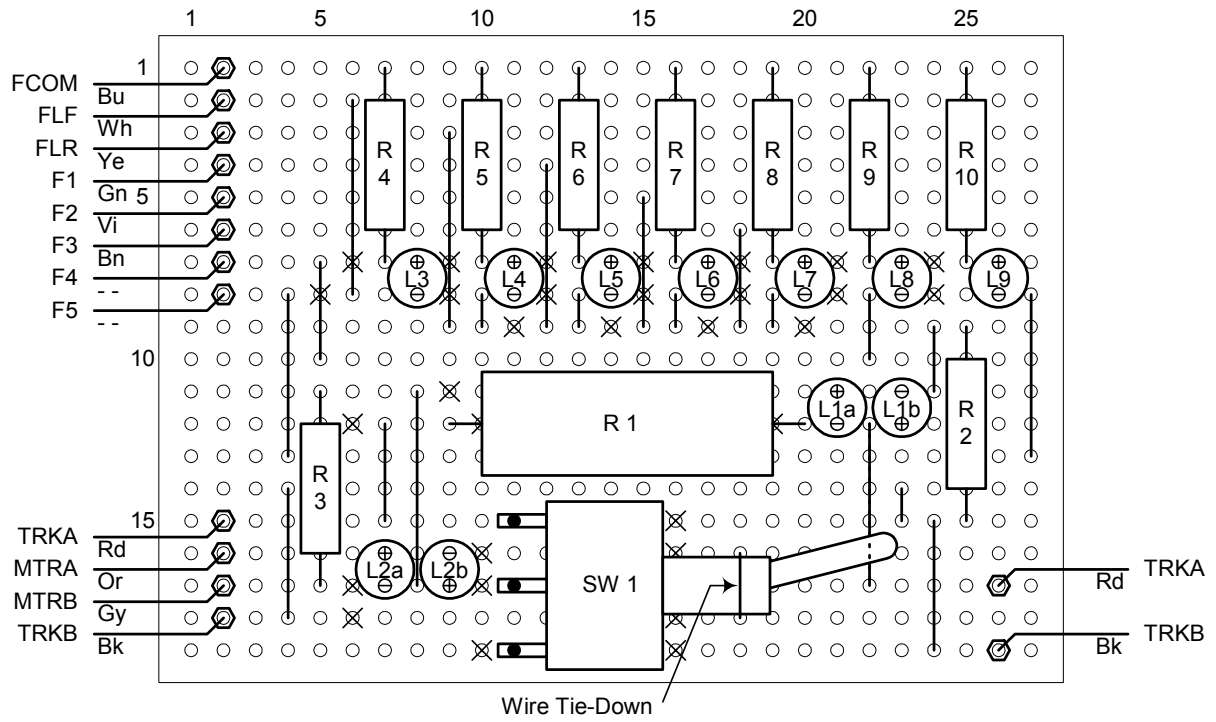

Decoder Tester

DCC_TESTER_BOARD.VSD 14 October 2004

Stripboard Layout

Copyright © JT Chamberlain 1999 - 2004 All rights reserved